

a: Strap / Verschlussband
1:1

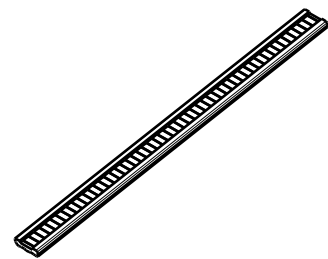

a: Strap / Verschlussband

Length 500m on reel/
Laenge 500m auf Spule

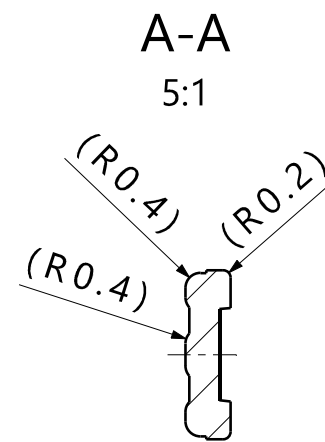
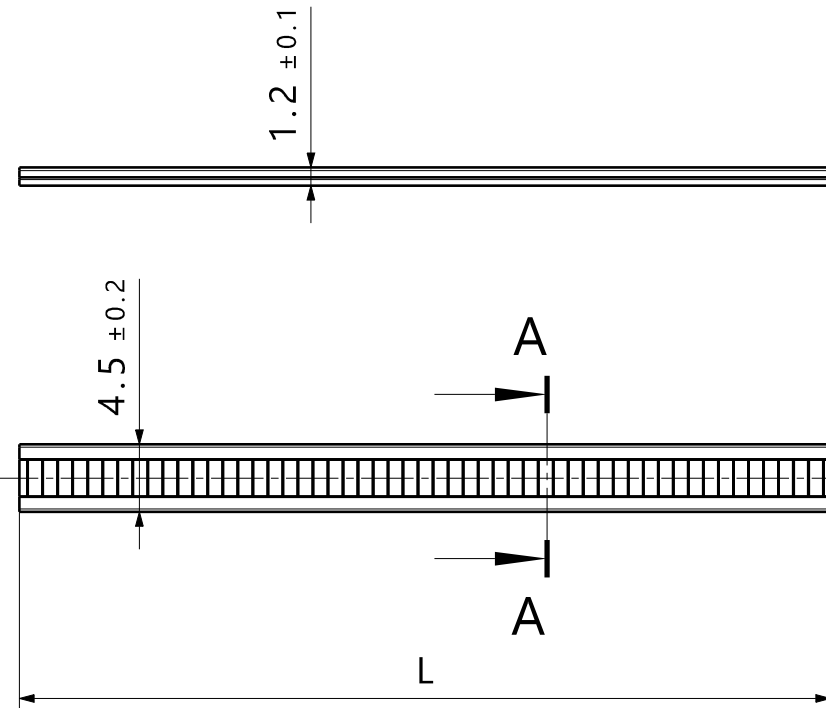

Printed copy for information only/
Ausdruck nur zur Information

ASSEMBLING POSSOBLITY/
MONTAGEMOEGLICHKEIT

1:1

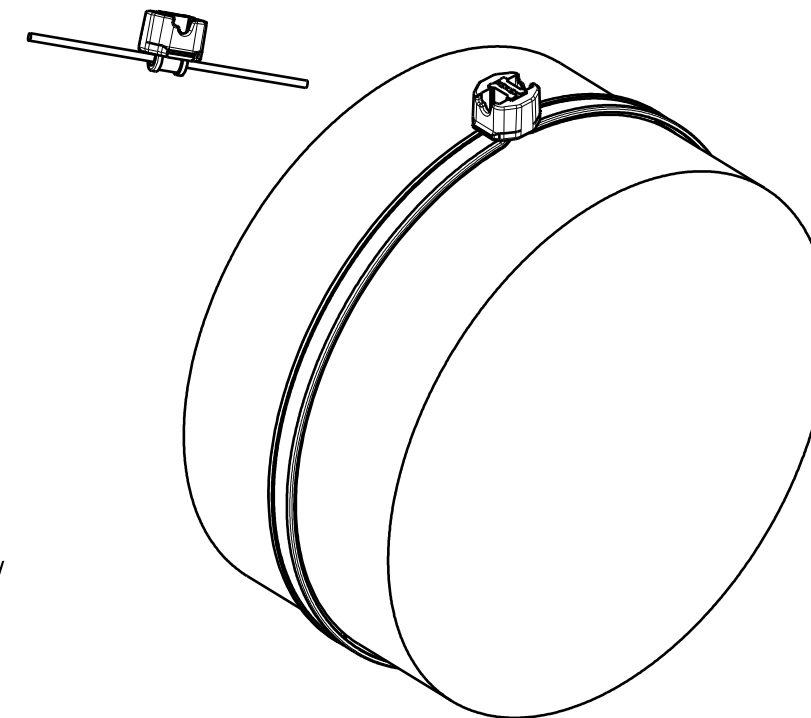

b: Closure / Verschlusskopf
1:1

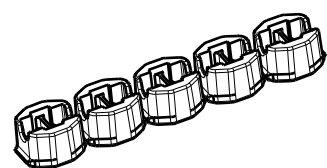

b: Closure / Verschlusskopf

5000 Closure from roll magazine/
5000 Koepfe von Rollenmagazin

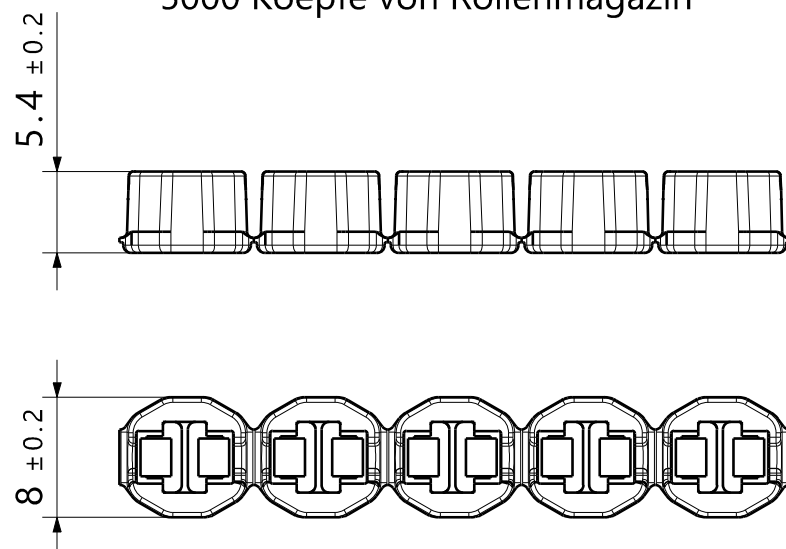

Specification:

- Performance requirements at equilibrium condition standard atmosphere 23 °C / 50% RH

- Material: a: PA6.6 impact modified, heat- and UV-stabilized
- b: PA6.6 heat- and UV-stabilized

- Material color: a.,b.: black optional nature

- Bundle Ø: 1 - 80mm

- Tensile force: 220N

The manufacturing-related geometry changes (injection point, ejectors marks, etc.) allowed. Design of the details are left to suppliers discretion.

Spezifikation:

- Leistungsanforderung im Gleichgewichtszustand Normalklima 23 °C / 50% RH

- Material: a: PA6.6 schlagzaeh modifiziert, hitze- und UV-stabilisiert
- b: PA6.6 hitze- und UV-stabilisiert

- Material Farbe: a.,b.: schwarz w.w. natur

- Buendel Ø: 1 - 80mm

- Schlaufenhaltekraft: 220N

Durch das Herstellverfahren bedingte Geometrieaenderungen (Anspritzung, Auswerfermarkierungen, etc.) zulaessig. Einzelheiten der Ausfuehrung bleiben dem Hersteller ueberlassen.

Revision Level		
Drawing	State	Part
04.4	Design Release	02.1
Changed	Date (YYYY/MM/DD)	
Villbrandt	2020/10/21	
Approved	Date (YYYY/MM/DD)	
B.Schiwek	2020/10/21	

Revision Record	
Drawing and closure geometry revised	

All drawing revisions are stored in CAD PDM database

The copyright of this drawing is reserved by HellermannTyton.

Drawn	Date (YYYY/MM/DD)
Steiner	2005/08/30
Approved	Date (YYYY/MM/DD)
Spiesz	2005/08/30

Units: mm
HellermannTyton
www.HellermannTyton.com

Title		Scale	
Strap and closure ATS3080		2:1	
Drawing-No		Global Project Number	
14.1883		12-0093	
		Format A3	
		Sheet 1 / 1	